

**Distance sensors**

**OADR 20I6575/S14F**

**dimension drawing**

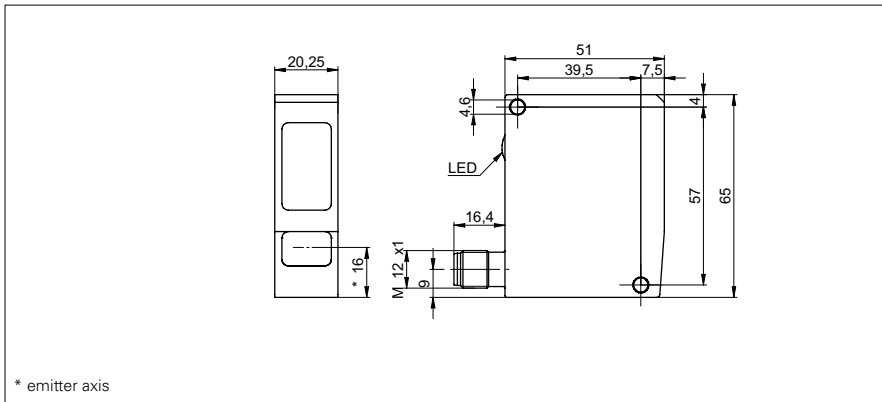

**general data**

|                        |                        |
|------------------------|------------------------|
| measuring distance Sd  | 50 ... 300 mm          |
| special type           | Washdown design        |
| adjustment             | external               |
| Teach-in range min.    | > 5 mm                 |
| power on indication    | LED green              |
| soiled lens indicator  | LED red                |
| resolution             | 0,01 ... 0,33 mm       |
| linearity error        | ± 0,03 ... ± 1 mm      |
| light source           | pulsed red laser diode |
| wave length            | 650 nm                 |
| laser class            | 2                      |
| beam type              | line                   |
| beam width             | 2,5 mm                 |
| beam height            | 4 ... 12 mm            |
| temperature drift      | < 0,03 % Sde/K         |
| approvals/certificates | Ecolab                 |

**electrical data**

|                                    |                            |
|------------------------------------|----------------------------|
| response time / release time       | < 0,9 ms                   |
| voltage supply range +Vs           | 12 ... 28 VDC              |
| current consumption max. (no load) | 100 mA                     |
| output circuit                     | analog                     |
| output signal                      | 4 ... 20 mA / 0 ... 10 VDC |
| load resistance (analog I)         | < (+Vs - 6 V) / 0,02 A     |
| load resistance (analog U)         | > 100 kOhm                 |
| output current                     | < 100 mA                   |
| alarm output                       | PNP                        |
| short circuit protection           | yes                        |
| reverse polarity protection        | yes, Vs to GND             |

**photo**



**connection diagram**

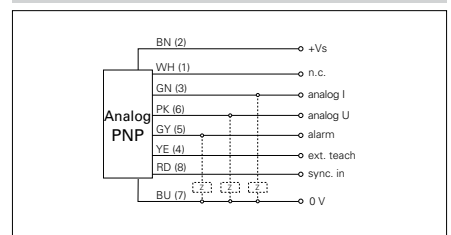

**alignment of the laser line**



**Distance sensors**
**OADR 20I6575/S14F**
**mechanical data**

|                  |                              |
|------------------|------------------------------|
| width / diameter | 20,3 mm                      |
| height / length  | 65 mm                        |
| depth            | 51 mm                        |
| type             | rectangular                  |
| housing material | stainless steel 1.4404 (V4A) |
| front (optics)   | PMMA                         |
| connection types | connector M12 8 pin          |

**ambient conditions**

|                        |                   |
|------------------------|-------------------|
| ambient light immunity | < 8 kLux          |
| operating temperature  | 0 ... +50 °C      |
| protection class       | IP 69K & proTect+ |

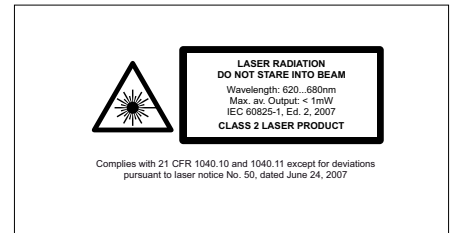
**laser warning**

*proTect<sup>+</sup>*

- Sensor FDA compliant and Ecolab approved
- sensitivity adjustable: via Teach-in wire input